

Atomic Physics at GSI: An Outlook

H. Backe¹, H.F. Beyer², F. Bosch², A. Bräuning-Demian², S. Hagmann^{2,3}, D.C. Ionescu²,
K. Jungmann², H.-J. Kluge², C. Kozhuharov², Th. Kühl², D. Liesen², R. Mann²,
P.H. Mokler², W. Quint², **Th. Stöhlker**^{2,3}

¹Universität Mainz, Germany

²GSI-Darmstadt, Germany

³IKF, Universität Frankfurt, Germany

AP WORKSHOP 2002, GSI

Atomic Physics at Accelerators

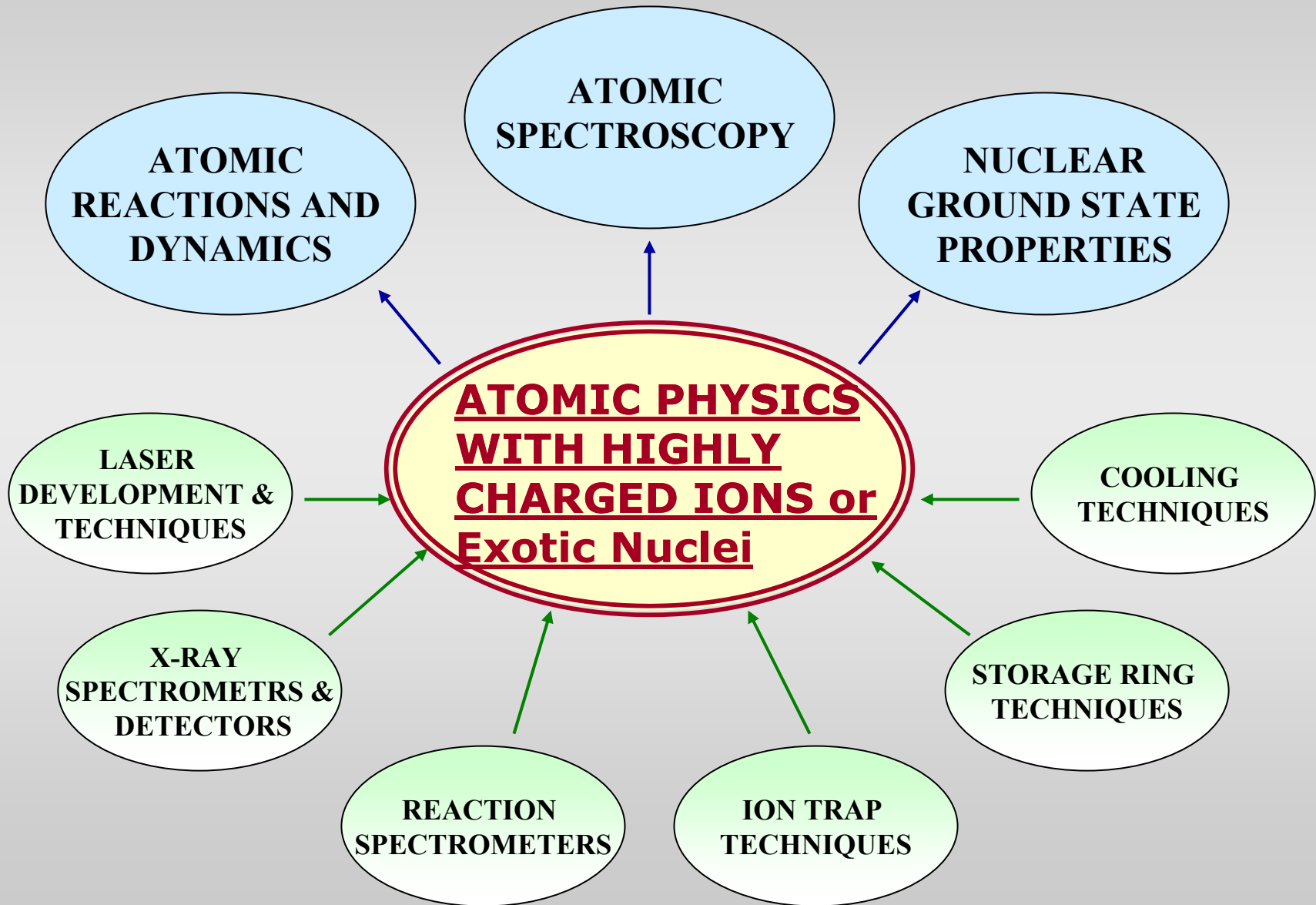

Self Energy



Vacuum Polarization

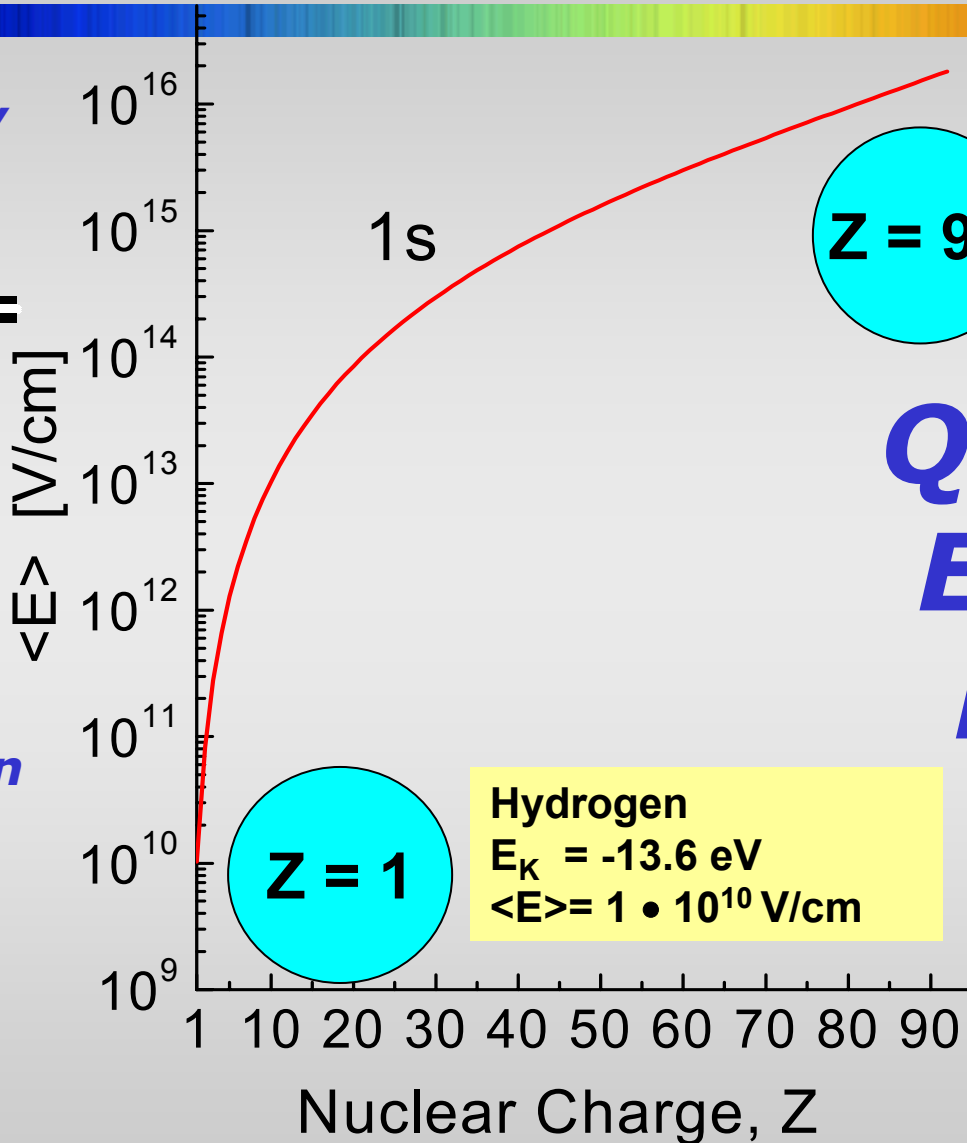
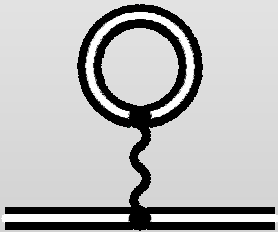

H-like Uranium
 $E_K = -132 \cdot 10^3 \text{ eV}$
 $\langle E \rangle = 1.8 \cdot 10^{16} \text{ V/cm}$

Z = 92

**Quantum
Electro-
Dynamics**

Z = 1

Hydrogen
 $E_K = -13.6 \text{ eV}$
 $\langle E \rangle = 1 \cdot 10^{10} \text{ V/cm}$

1s-ground state: increase of the electric field strength by six orders of magnitude

Test of Quantum Electrodynamics

Uranium-Ion

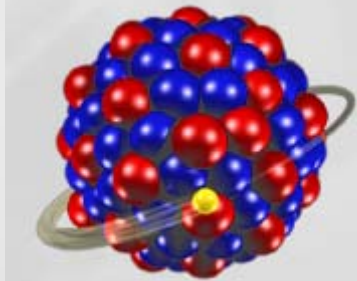

$Z=92$; $E_b = 132 \text{ KeV}$
 $Z \cdot \alpha \approx 1$

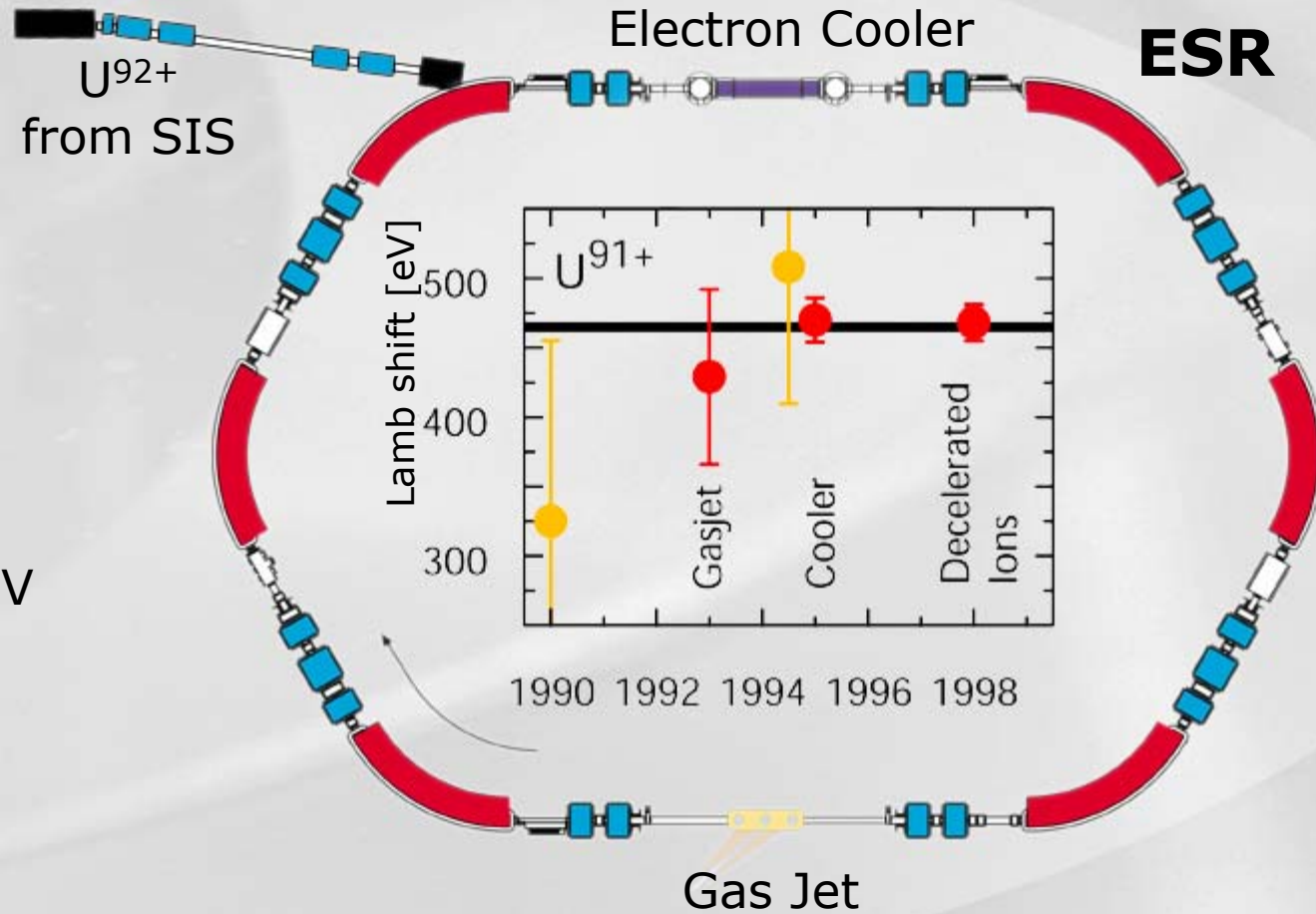

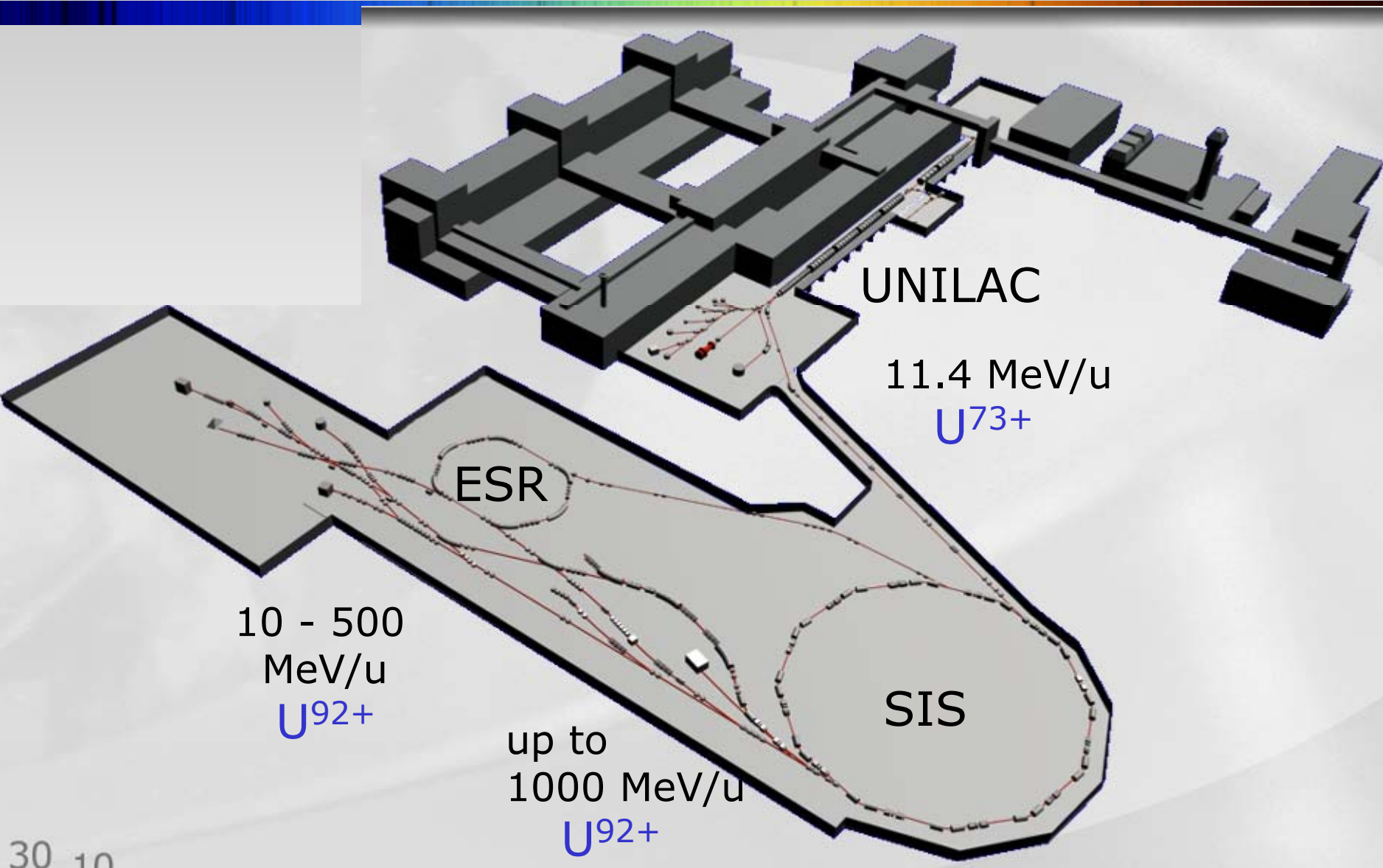

UNILAC

11.4 MeV/u
 U^{73+}

ESR

10 - 500
MeV/u
 U^{92+}

up to
1000 MeV/u
 U^{92+}

SIS

Electromagnetic Phenomena under Extreme & Unusual Conditions

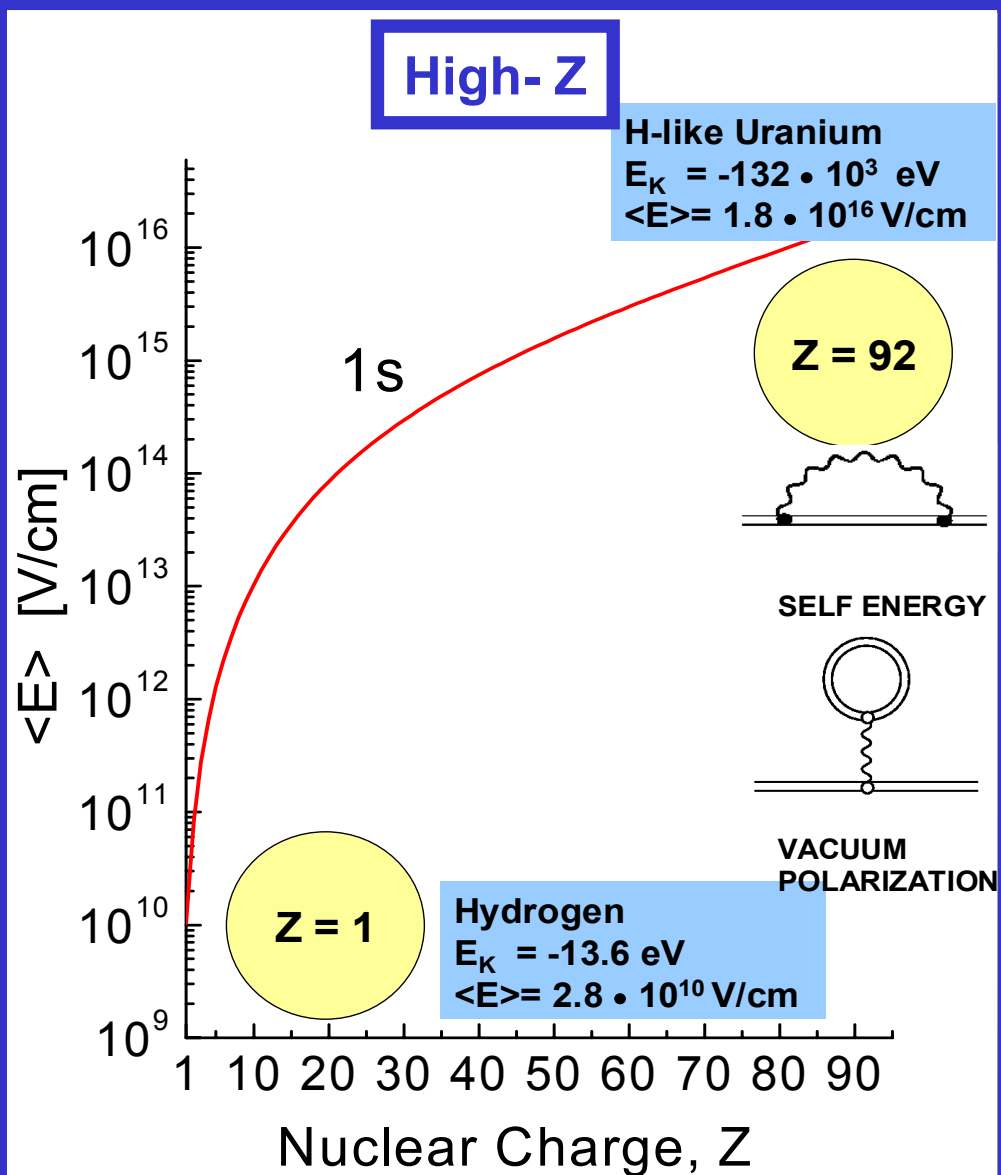

1s-ground state: increase of the electric field strength by six orders of magnitude

High- γ

Collision times in the sub-attosecond regime
($10^{-22} \text{ s} < t < 10^{-18} \text{ s}$)

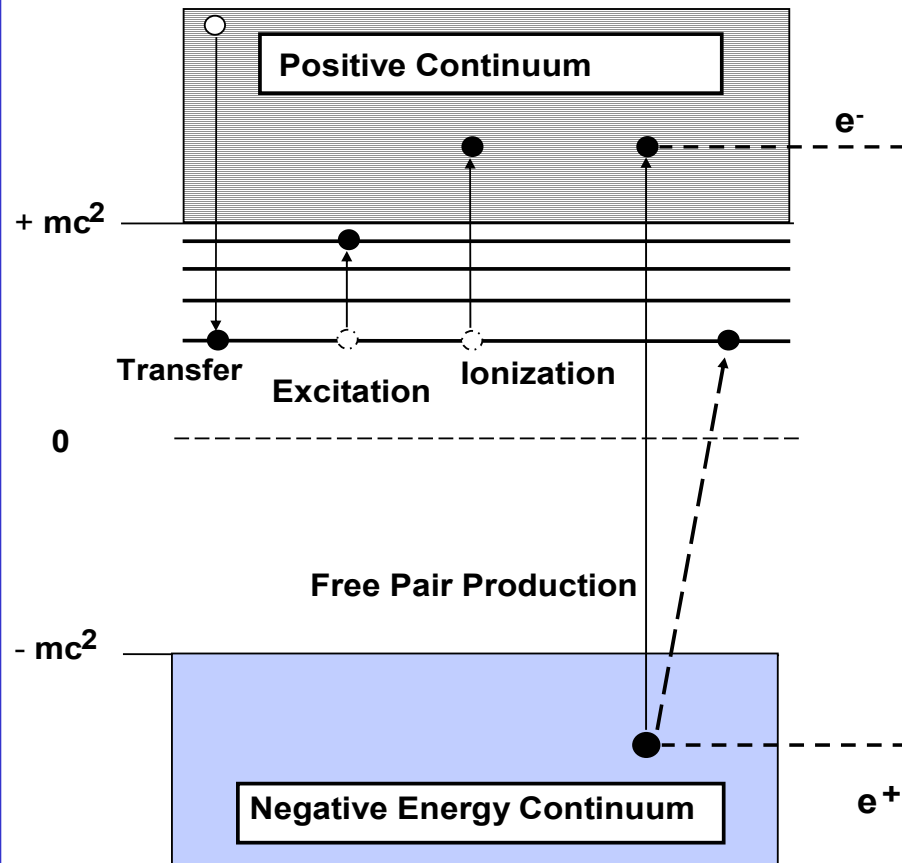

The New GSI Accelerator Project

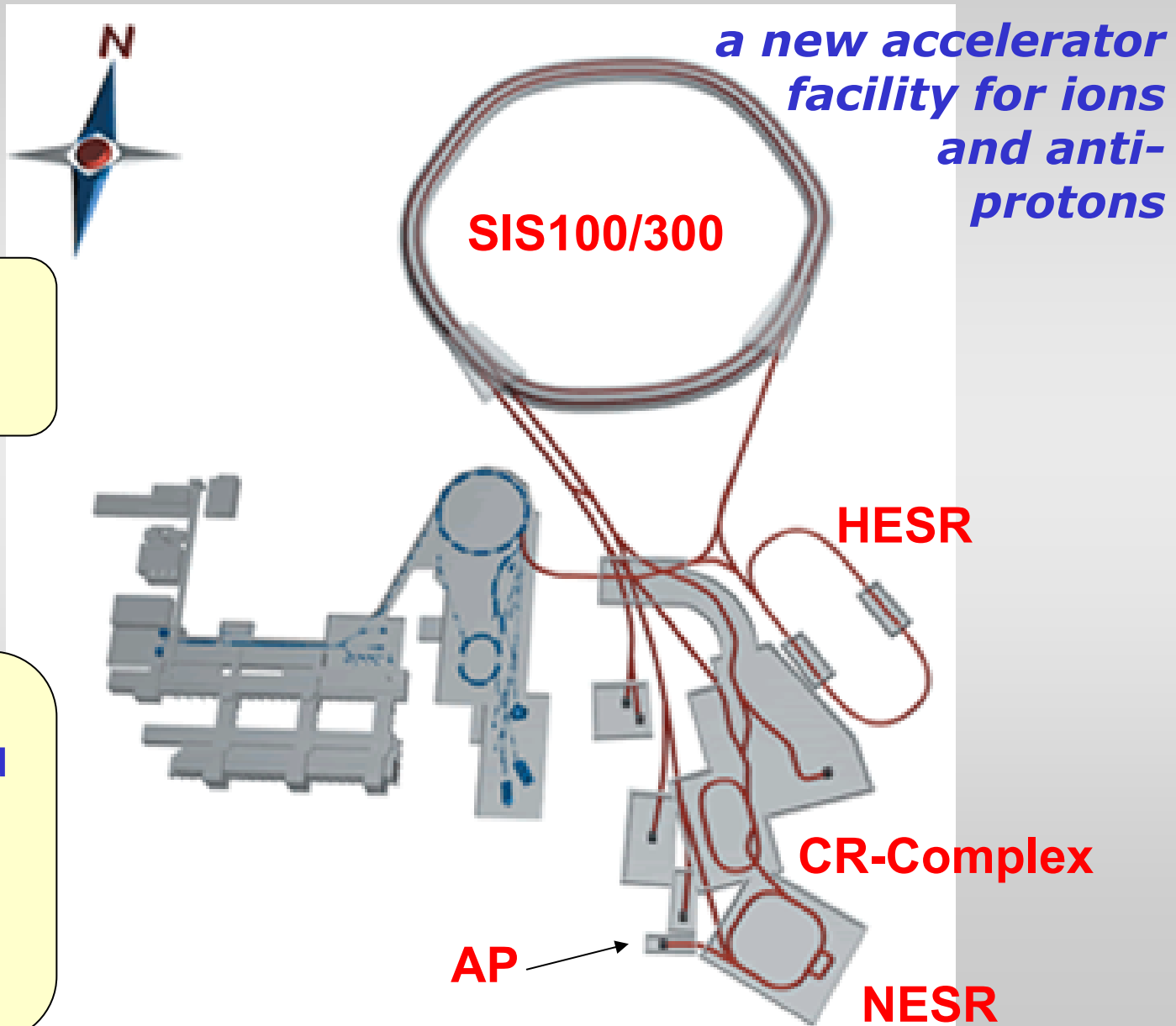

1×10^{12} 1/s
for U^{28+} at
1 GeV/u

Parameter
stored and cooled
antiprotons

90 GeV protons
34 GeV/u U^{92+}

Relativistic Collision Dynamics in Strong Electromagnetic Fields

Test of Quantum Electrodynamics in Strong Fields

**Atomic Physics Techniques Applied
to Nuclear Physics**

**Atomic Physics Techniques Applied to
Fundamental Tests other than QED**

**Ions and Electrons in Highly-Intense,
Femtosecond Laser Fields**

High Energy Synchrotron (SIS100/300)

Parameter
90 GeV protons
34 GeV/u U⁹²⁺

laser ion-beam
interaction zone

high-energy cave

New Fragment Separator (SFRS)
[production of fragment beams]

Collector Ring Complex (CR)
[stochastic cooling for fragment beams]

New Experimental Storage Ring (NESR)
[energies between 840 MeV/u down to 3 MeV/u]

Internal and external
installations

High Energy Experimental Storage Ring (HESR)
[for antiprotons at energies up to 14 GeV]
Optional: heavy ions beams up to 6 GeV/u

Optional: internal target
experiments with HCl

High Precision Laser Spectroscopy by using the large Lorentz energy shift at high γ values

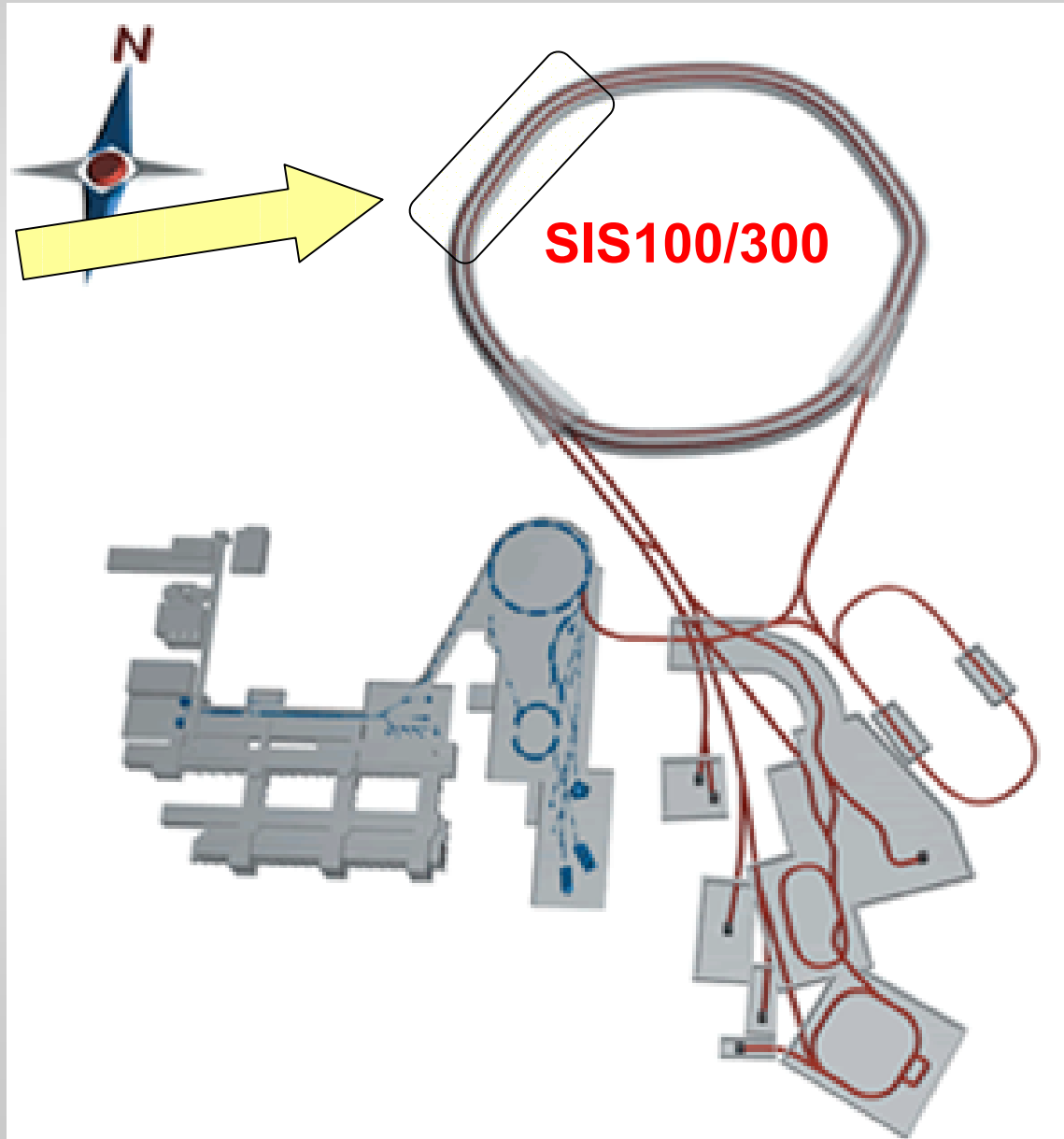
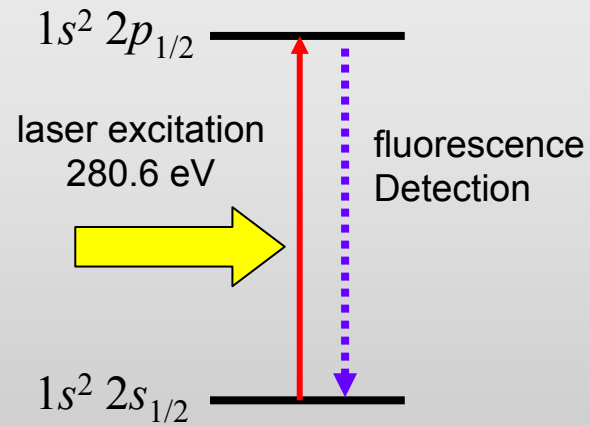

Precision Tests of QED in Strong Fields High-Z Li-Like Ions

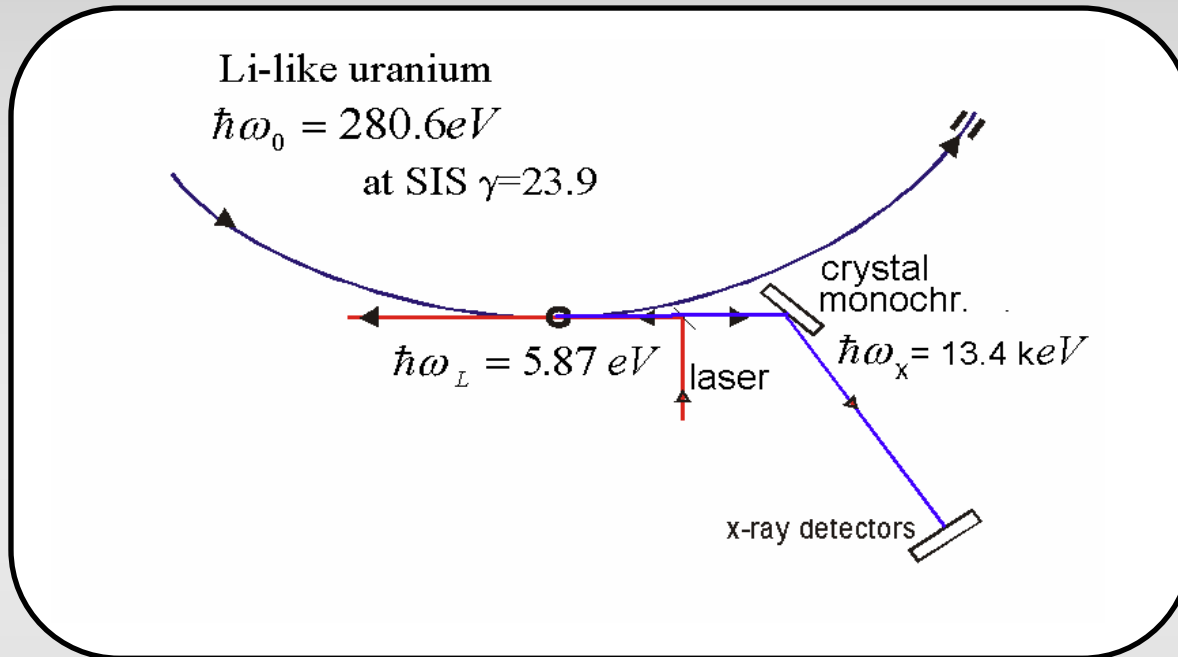

Lab. System (laser)

$$\hbar\omega_L = 5.87\text{eV}$$

$\gamma=23.9$



Projectile frame
excitation

$$\hbar\omega_0 = 280.6\text{eV}$$

fluorescence

$\gamma=23.9$



Lab. System
fluorescence

$$\hbar\omega_X = 13384\text{eV}$$

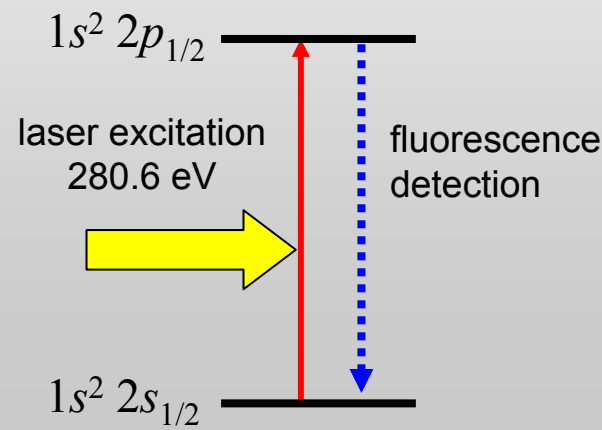

The **large Doppler shift** allows to use **visible laser** sources to excite transitions in the energy range up to **280 eV**, e.g. **2s-2p** transitions in lithium-like heavy ions

Precision Tests of QED in Strong Fields High-Z Li-Like Ions

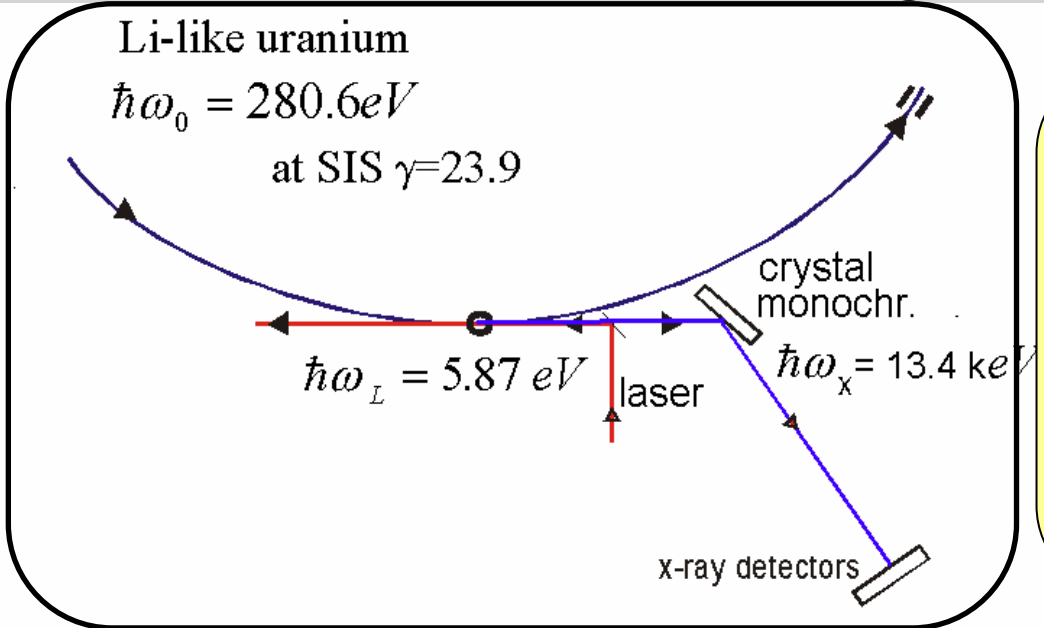

Expected accuracy for the
 280 eV transition: **0.007 eV**
 (currently best value:
 $280.59 \pm 0.09\text{ eV}$)

Only 100 ions are required

Further Applications

- measurement of nuclear charge radii for radioactive ion beams
- magnetic nuclear moments (hyperfine structure)

Electromagnetic Phenomena under Extreme & Unusual Conditions

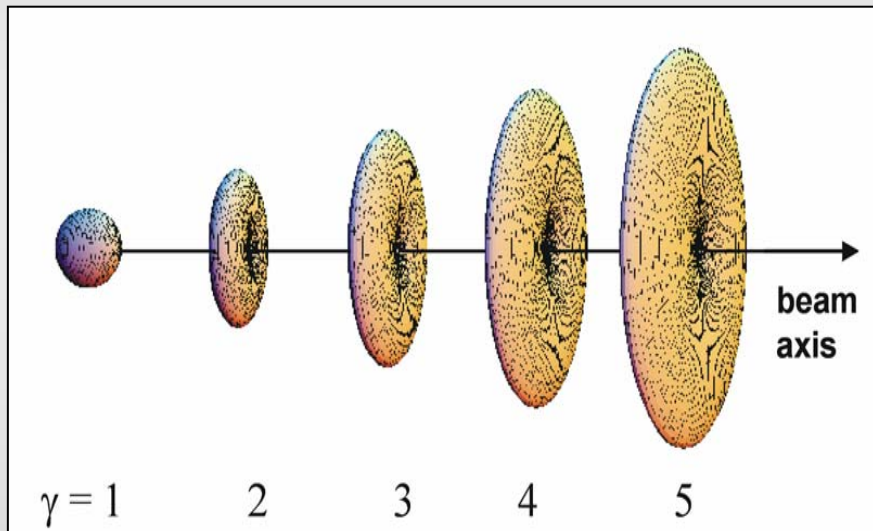

Dependence of the radial electric field strength for a point charge on the Lorentz factor γ

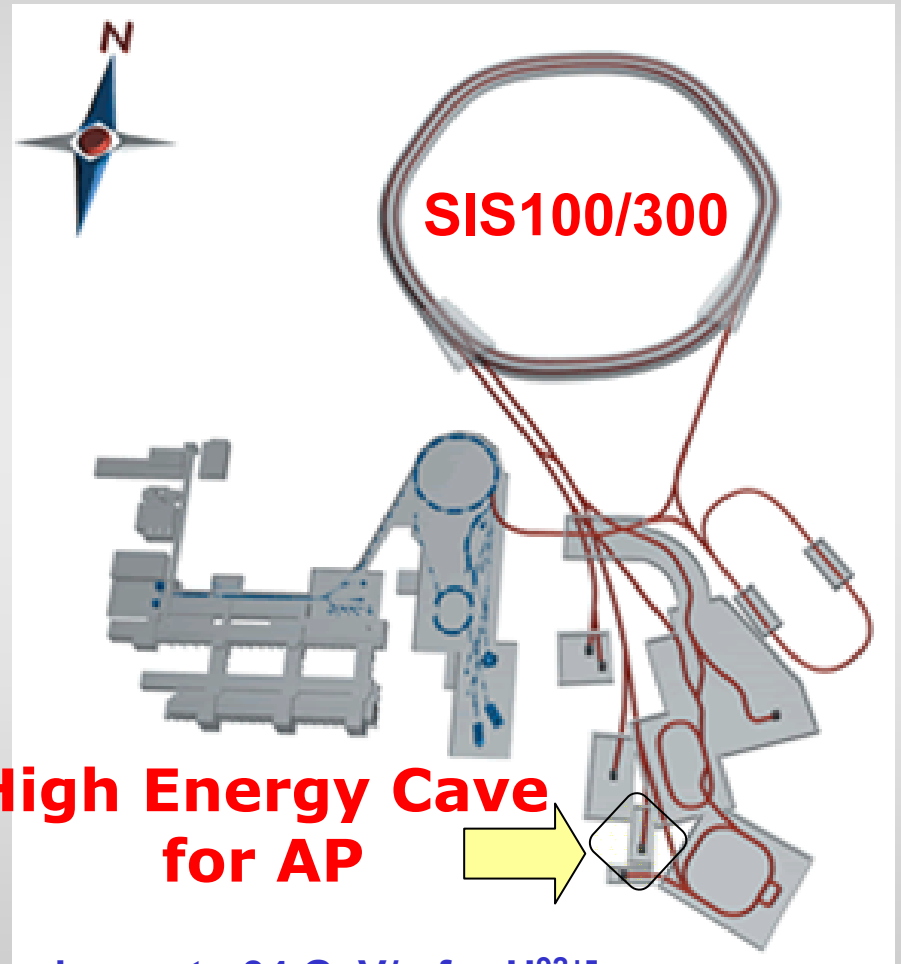

[energies up to 34 GeV/u for U^{92+}]

Electromagnetic Phenomena under Extreme & Unusual

In(γ) cross-section increase for all excitation like processes such as ionization or e^+e^- pair creation

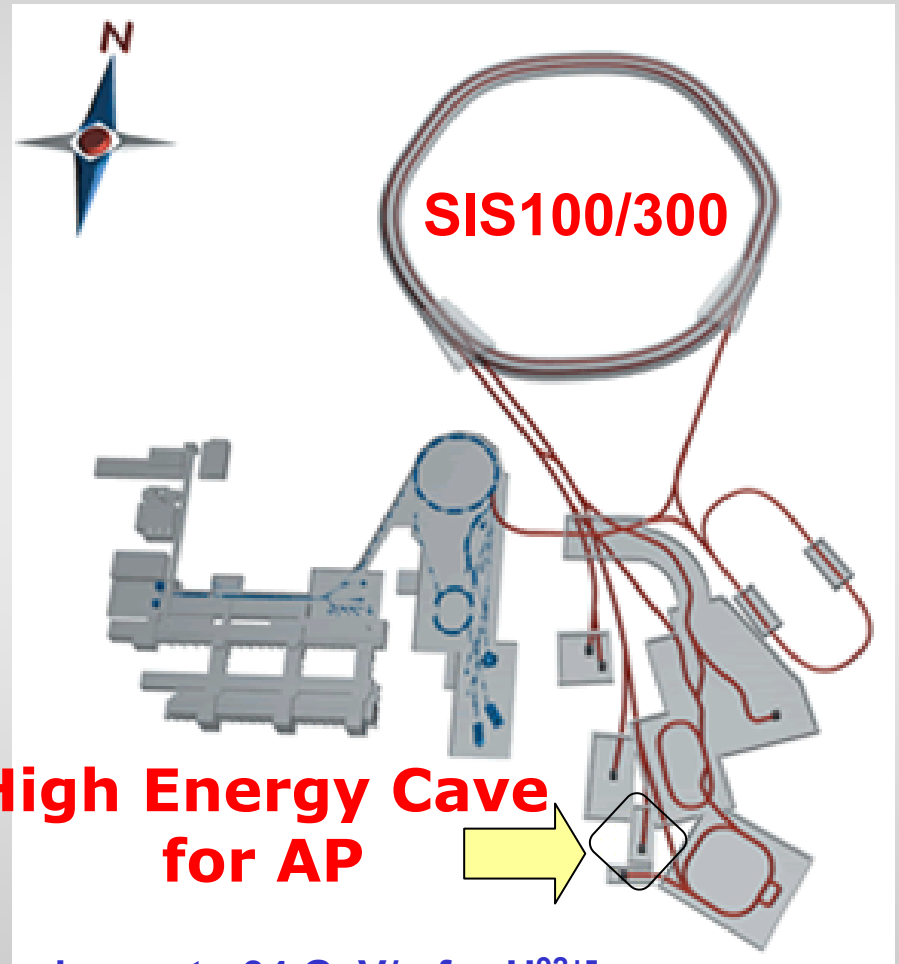
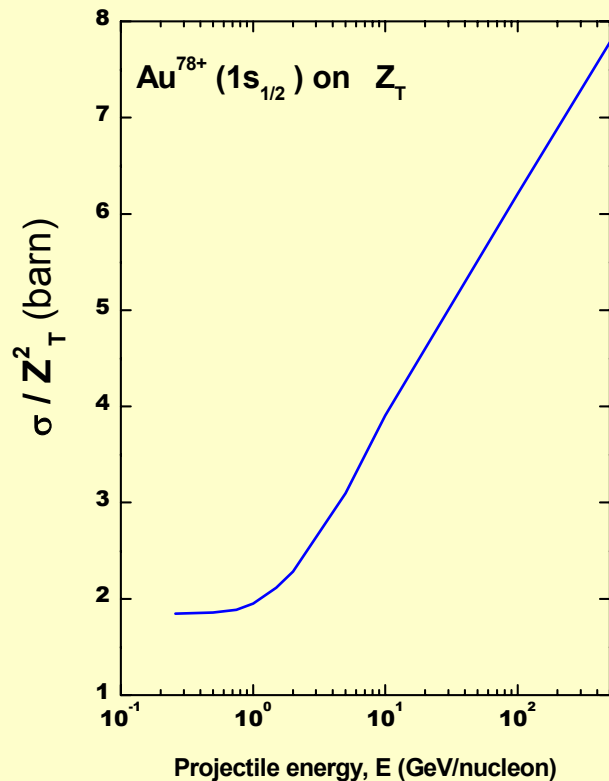

[energies up to 34 GeV/u for U^{92+}]

Collision Experiments at **SIS 300**

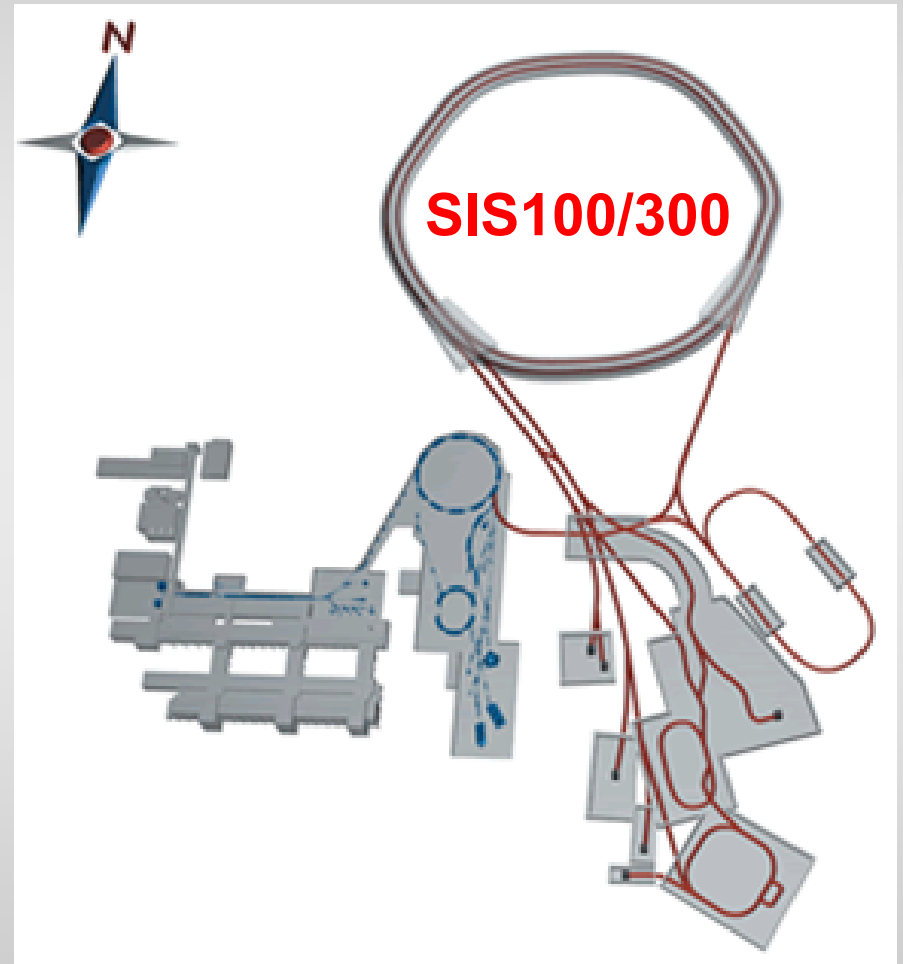
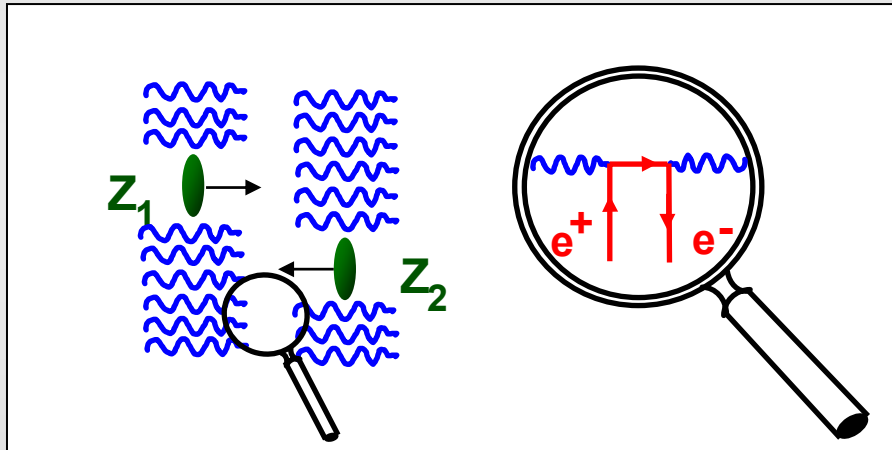

R. Schuch
Y. Yamazaki

The New ESR

Storage and Cooler Ring for
HCI, Antiprotons, Fragment Beams

Energies: 840 to 3 MeV/u

Circumference: **211 m** (ESR: 108 m)

Straight sections for exp. installations
18 m

Experimental installations

electron target

internal jet-target

laser-ion interaction zone

low-energy cave: cooled extracted ions

HITRAP

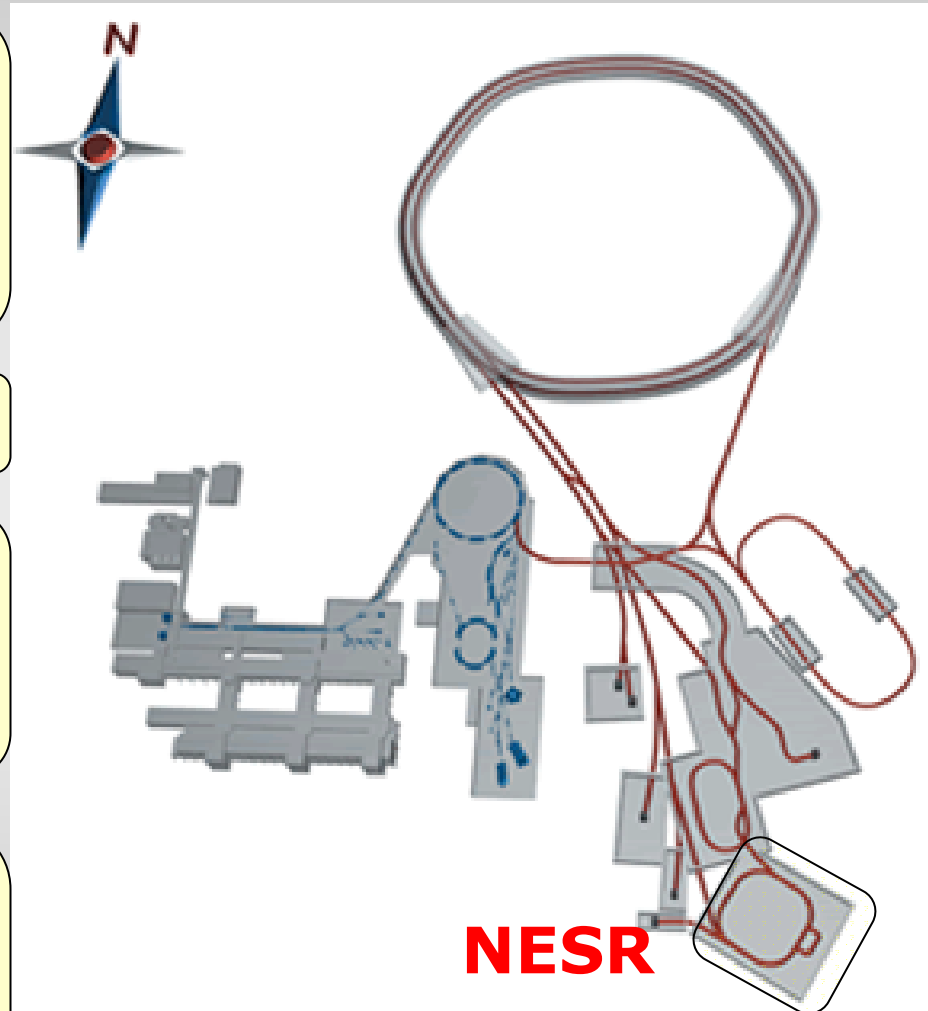

The New Experimental Storage Ring **NESR**

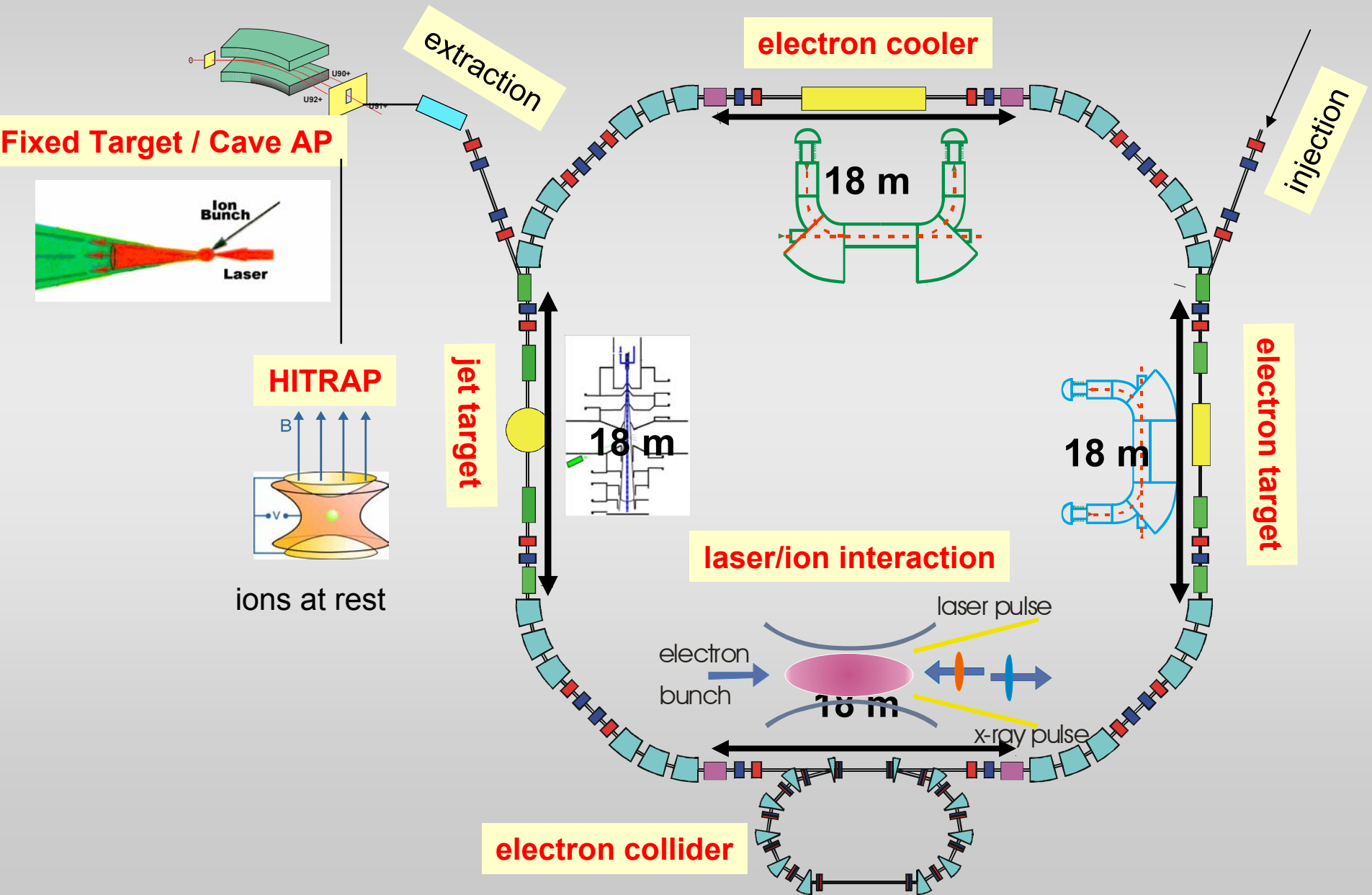

**DR experiments for Li-like heavy ions at the ESR:
The already achieved accuracy is comparable with the most precise x-ray experiments**

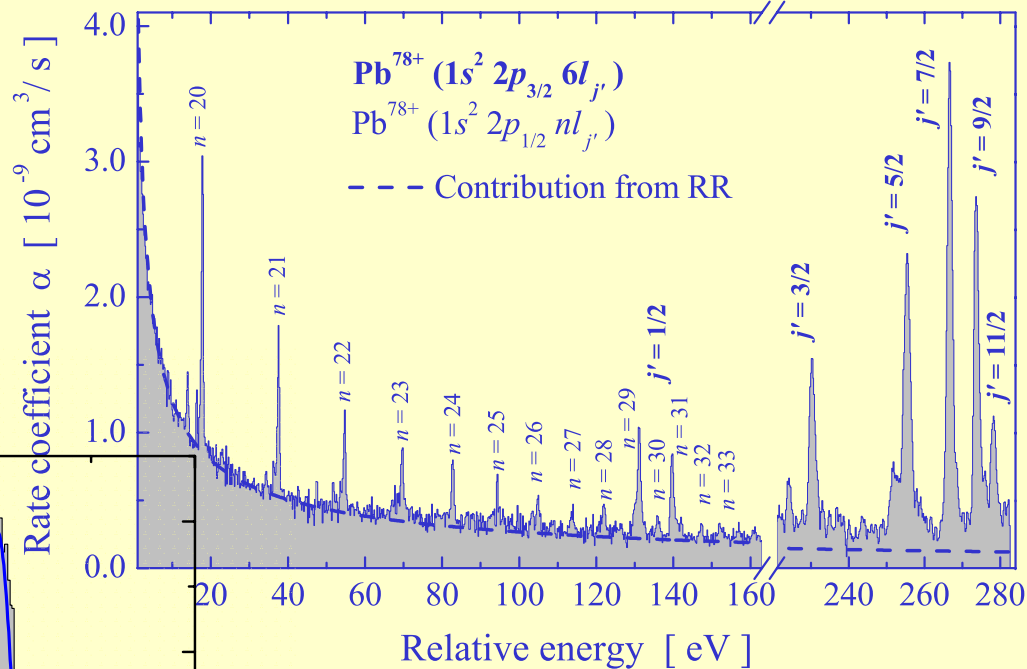
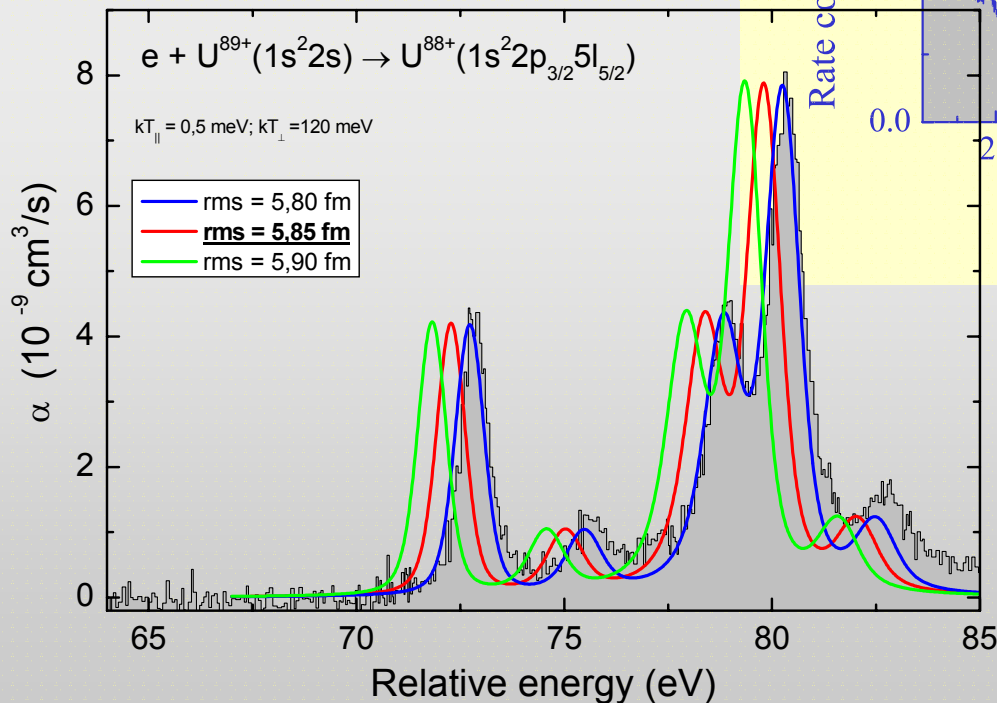

Experiment and theory for three different rms radii of ^{238}U

X-Ray Laser Spectroscopy on Lithium-like Radioactive Nuclei

Principle of an X-Ray Laser (XRL)

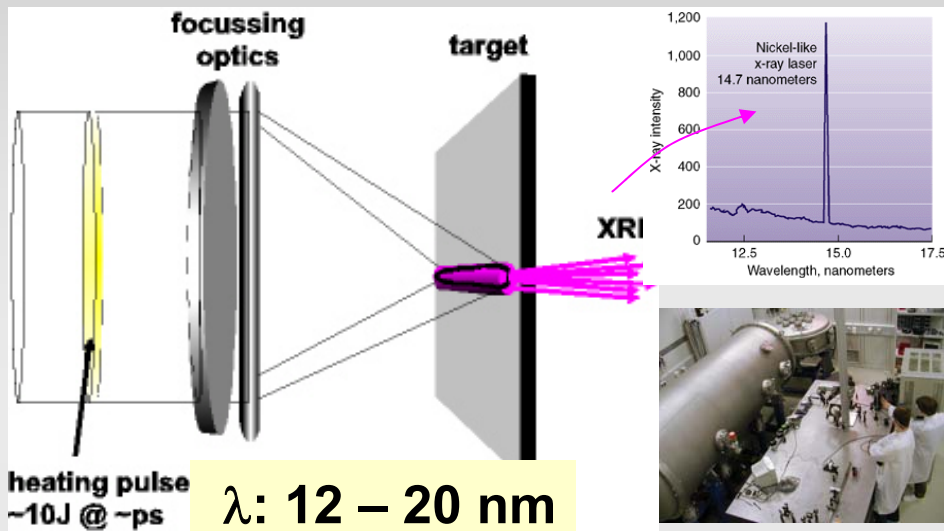

Excitation in the ESR/NESR

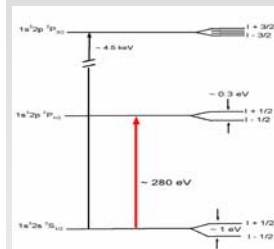
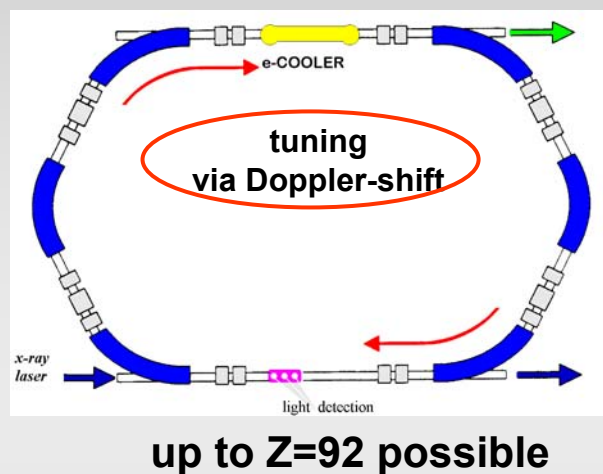

At NESR:
Wide Range
of
Accessible
Ions

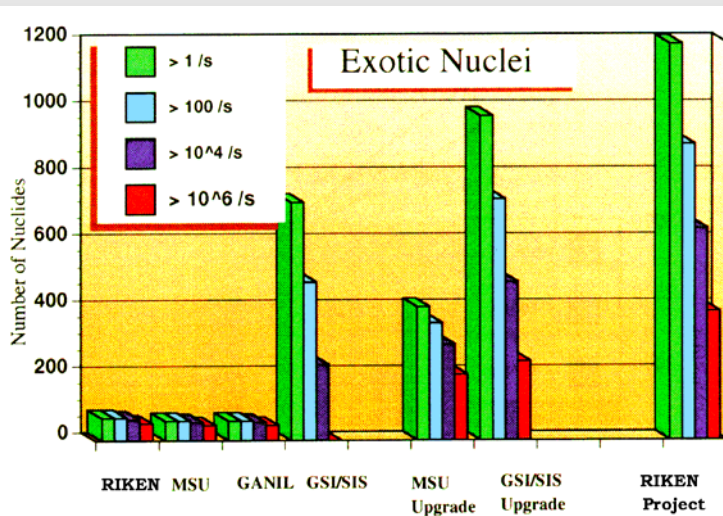

$$\Delta p/p \sim 5 \times 10^{-5}$$

$$\Delta E_{\text{Dopp.}}/E \sim 10^{-4} \dots 10^{-5}$$

E. Gaul

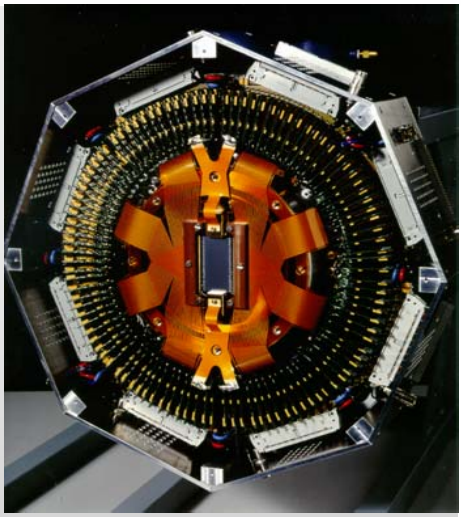
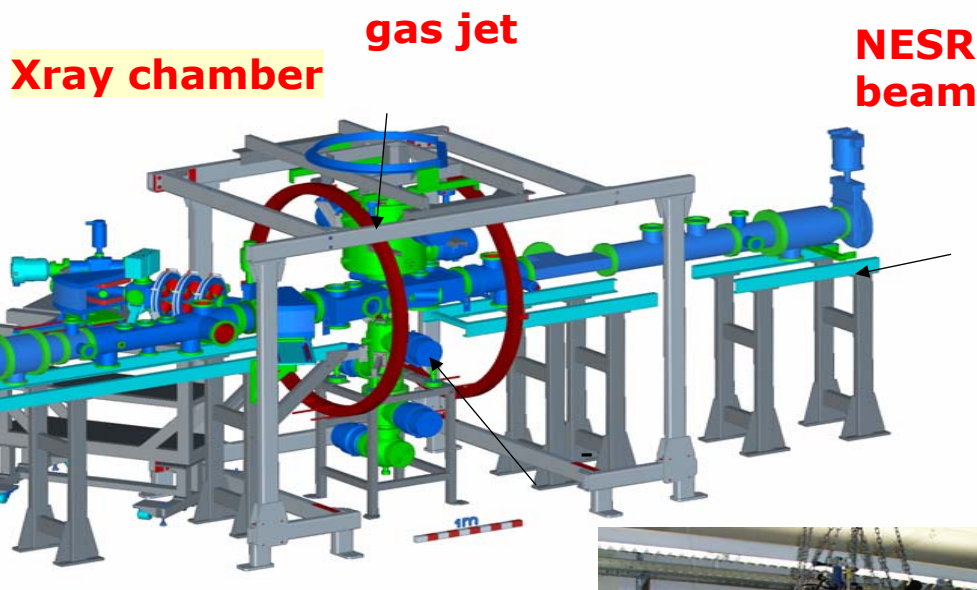
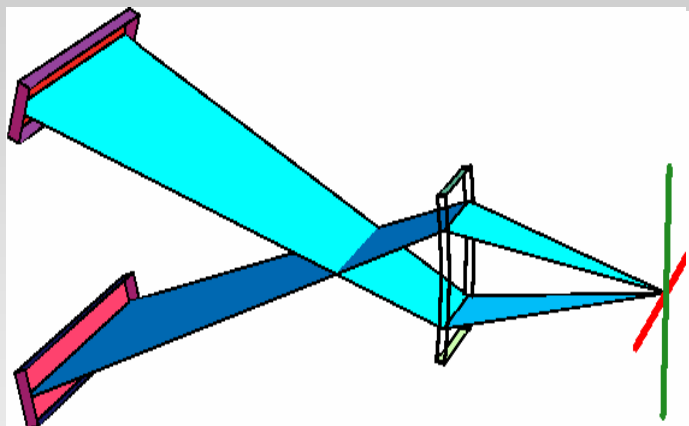

X-RAY SPECTROSCOPY
e.g.
precision spectroscopy
photon correlation studies
polarization phenomena

H. Beier et al.
Th. Stöhlker et al.

P. Egelhof et al.
E. Silver et al.



ELECTRON SPECTROSCOPY

high-resolution electron spectroscopy
complementary to the x-ray channel

S. Hagmann et al.
R. Moshhammer et al.

RECOIL ION MOMENTUM SPECTROSCOPY

impact parameter sensitive studies
(e,2e) processes in HCl atom collisions

S. Hagmann et al.
R. Mann et al.

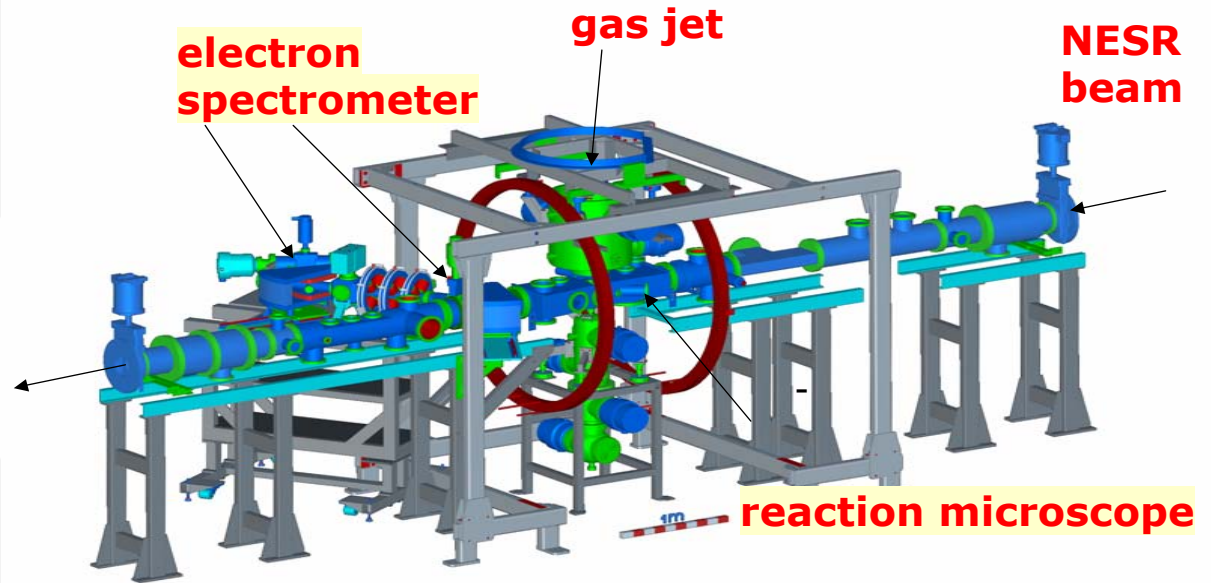

Ion-Solid-Cluster
channeling,
material modification,
fragmentation phenomena

A. Bräuning-Demian et al.
P. Mokler et al.

The **HITRAP** Project at GSI

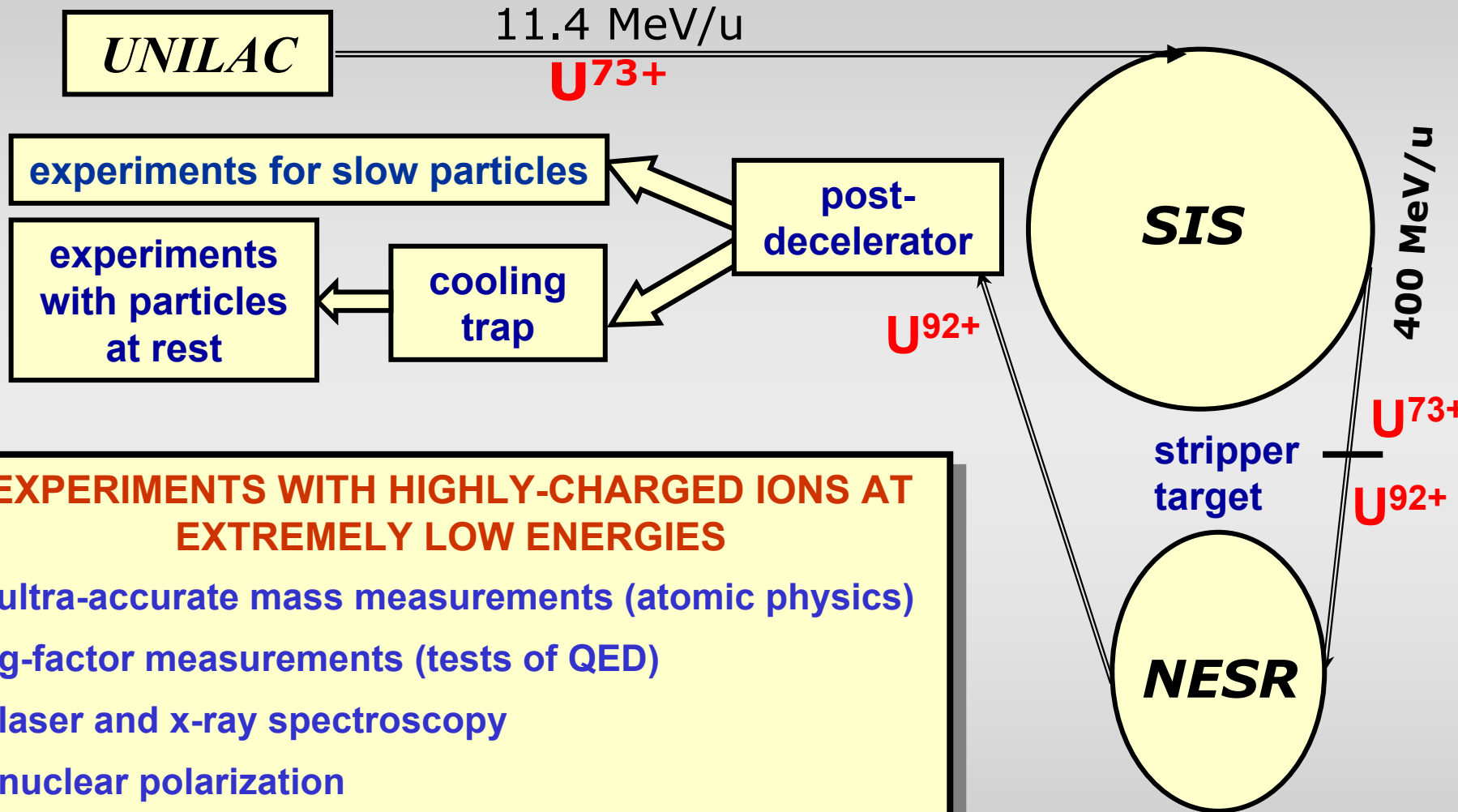

EXPERIMENTS WITH HIGHLY-CHARGED IONS AT EXTREMELY LOW ENERGIES

- ultra-accurate mass measurements (atomic physics)
- g-factor measurements (tests of QED)
- laser and x-ray spectroscopy
- nuclear polarization
- surface studies and hollow-atom spectroscopy
- collisions at very low velocities
- experiments with antiprotons at the NESR

**HITRAP
WORKSHOP**

HESR

Experiments with cooled relativistic HCI up to a Lorentz factor of $\gamma \approx 6$

Electron, positron (e^+e^- pairs), and photon spectroscopy at the internal target

Relativistic kinematics results in a **strongly enhanced resolution** for electron, positron, and photon spectroscopy

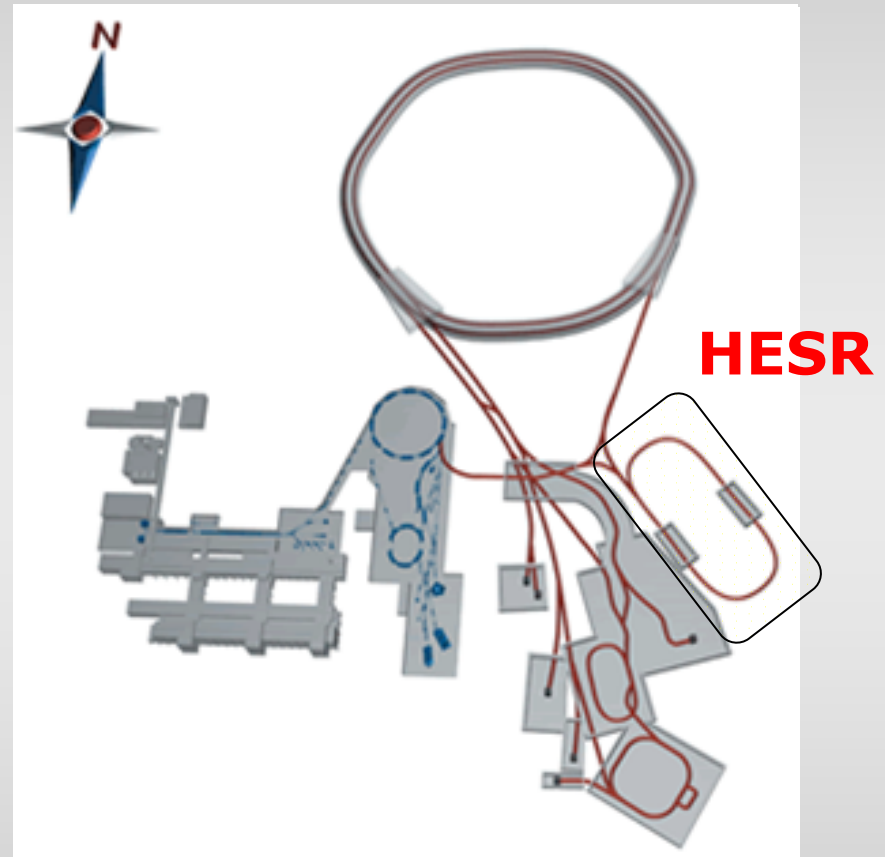

Lyman Transitions of Hydrogen-Like Uranium

Example: Zero-Degree Photon Spectroscopy

