

SISTA2019\_TA1\_LO

PHASESPACE PLOT

Fri Aug 23 16:24:10 CEST 2019

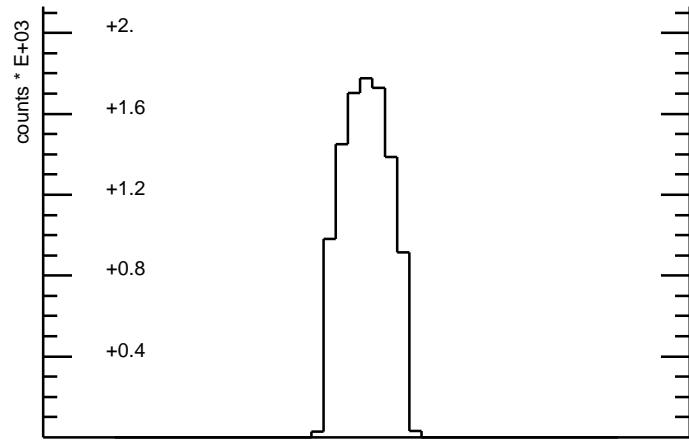

max. count: 1776

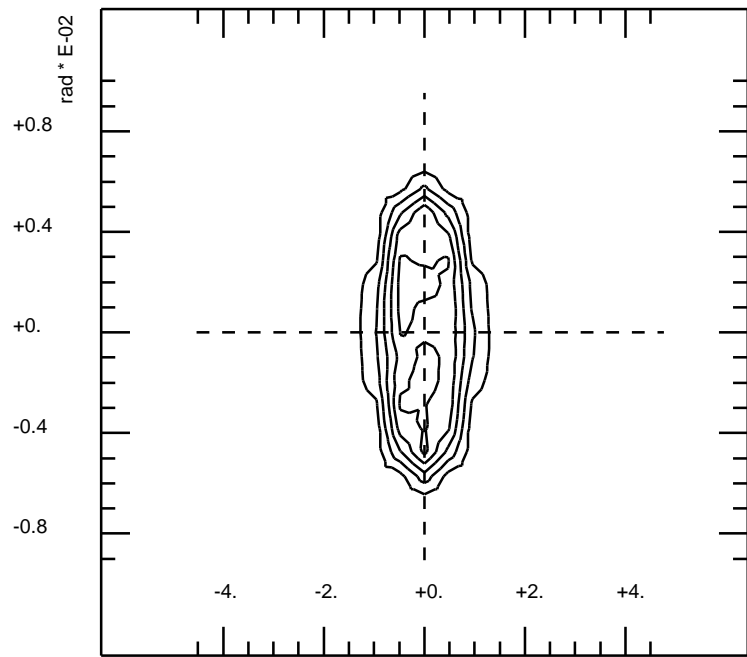

max. count: 320

m \* E-03

PHASESPACE PLOT OF (Xf,Af) AT 17.081 M

10000 PARTICLES STARTED  
10000 PARTICLES IN WINDOW

PARTICLES STARTED IN PHASESPACE

X = +- 0.00948641  
A = +- 0.00052707  
Y = +- 0.00564836  
B = +- 0.00088521  
G = + 0.00000000  
P = +- 0.00100000

NUMBER OF MASSES : 1  
NUMBER OF ENERGIES : 1

CALC MODE: SYSTEM MATRIX  
CALC ORDER: 3

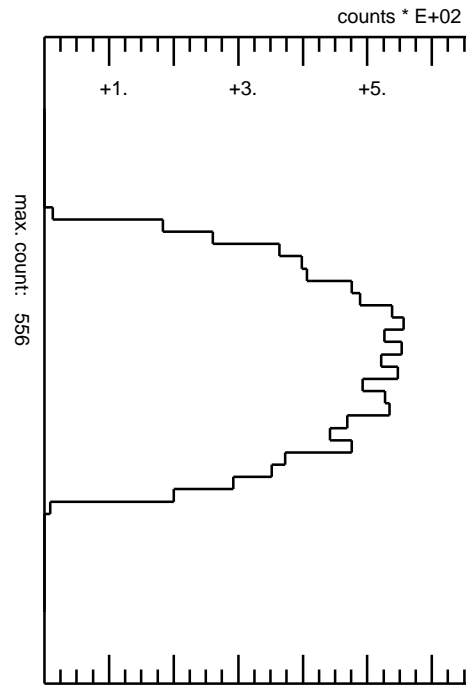

max. count: 556

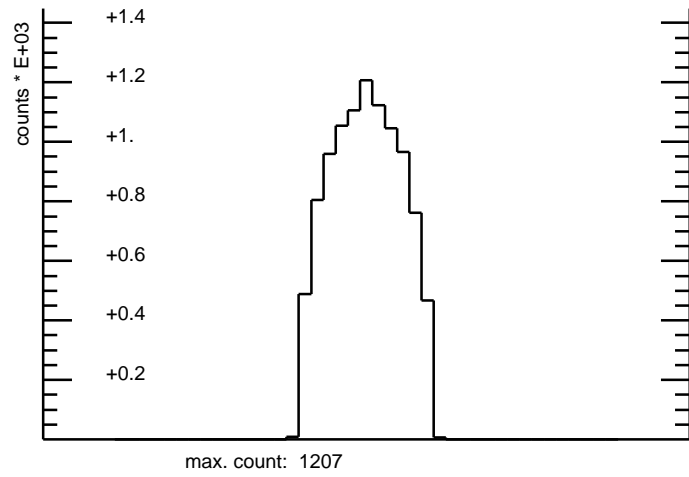

PHASESPACE PLOT OF (Yf,Bf) AT 17.081 M

10000 PARTICLES STARTED  
10000 PARTICLES IN WINDOW

PARTICLES STARTED IN PHASESPACE

X = +- 0.00948641  
A = +- 0.00052707  
Y = +- 0.00564836  
B = +- 0.00088521  
G = + 0.00000000  
P = +- 0.00100000

NUMBER OF MASSES : 1  
NUMBER OF ENERGIES : 1

CALC MODE: SYSTEM MATRIX  
CALC ORDER: 3

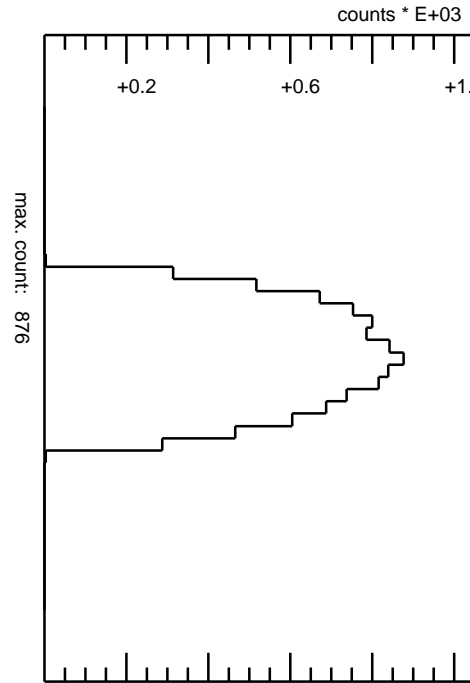
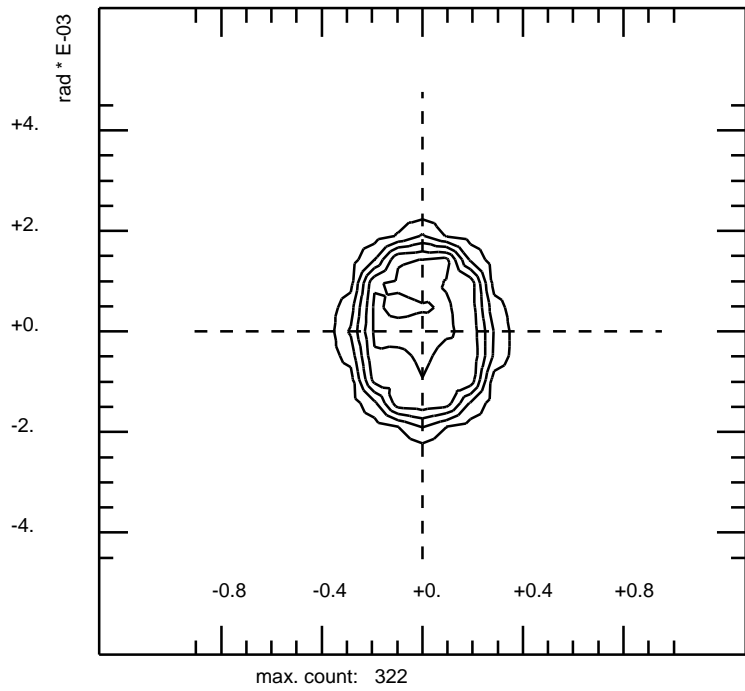

m \* E-02

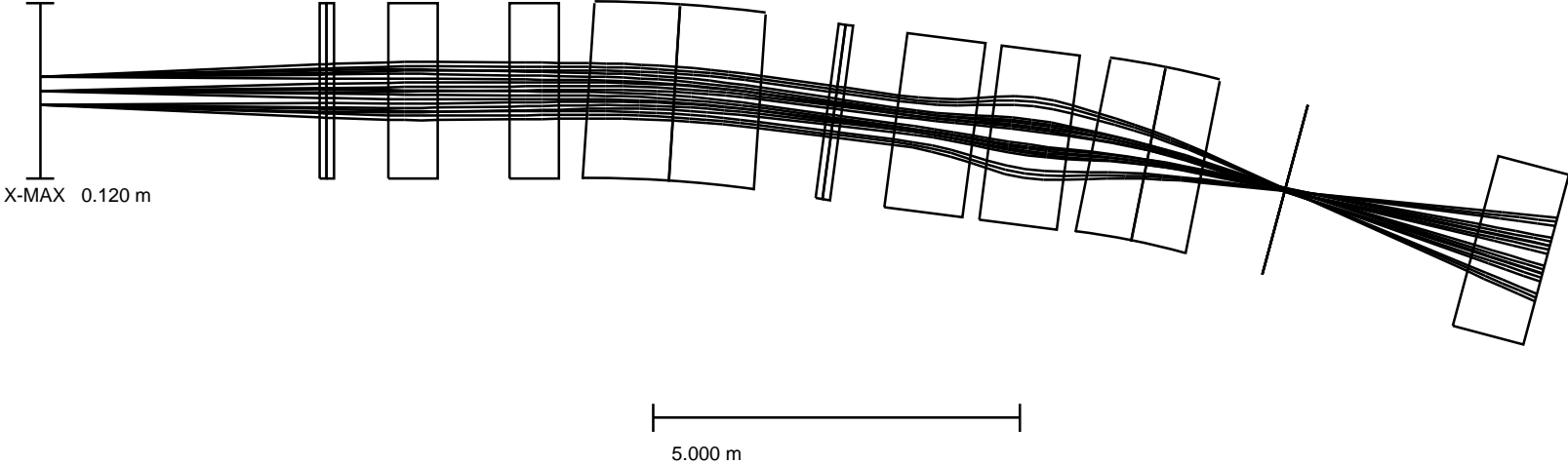

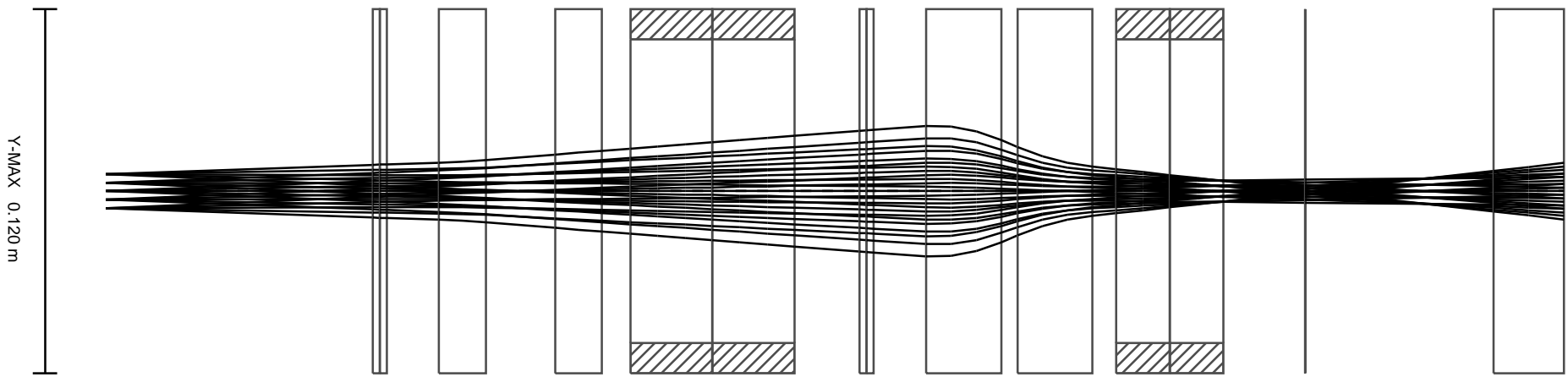
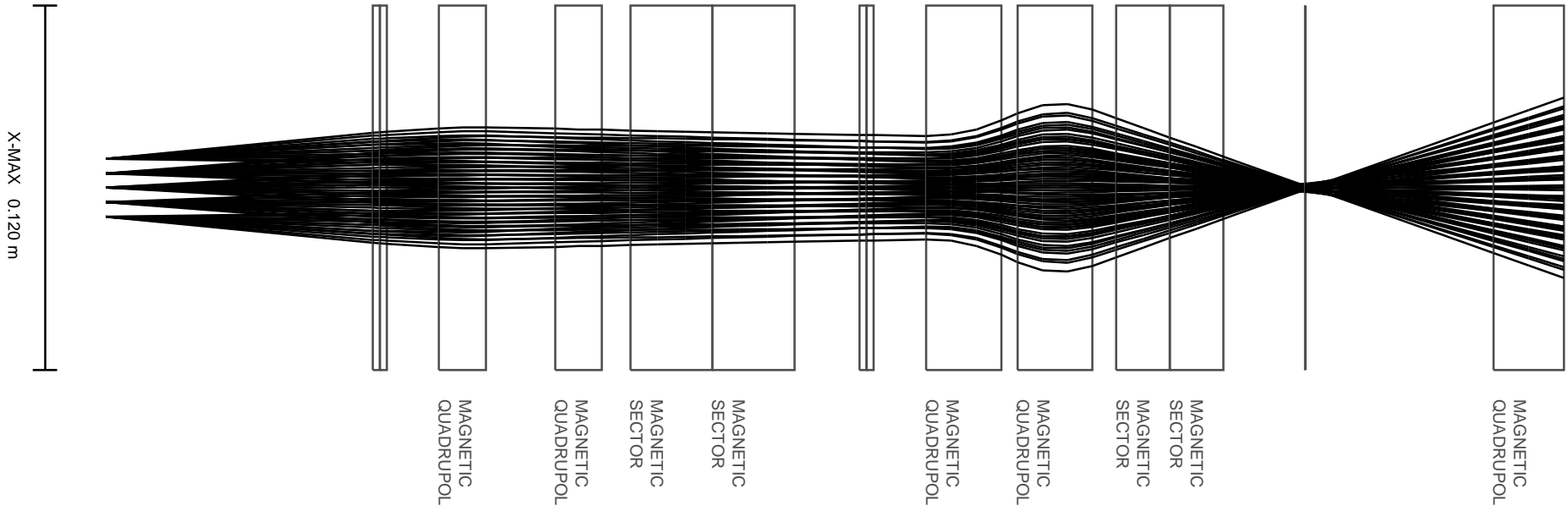

2.000 m

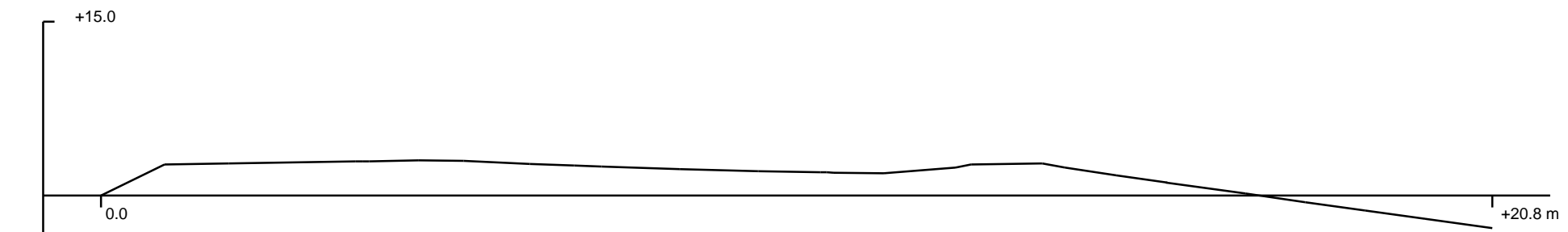
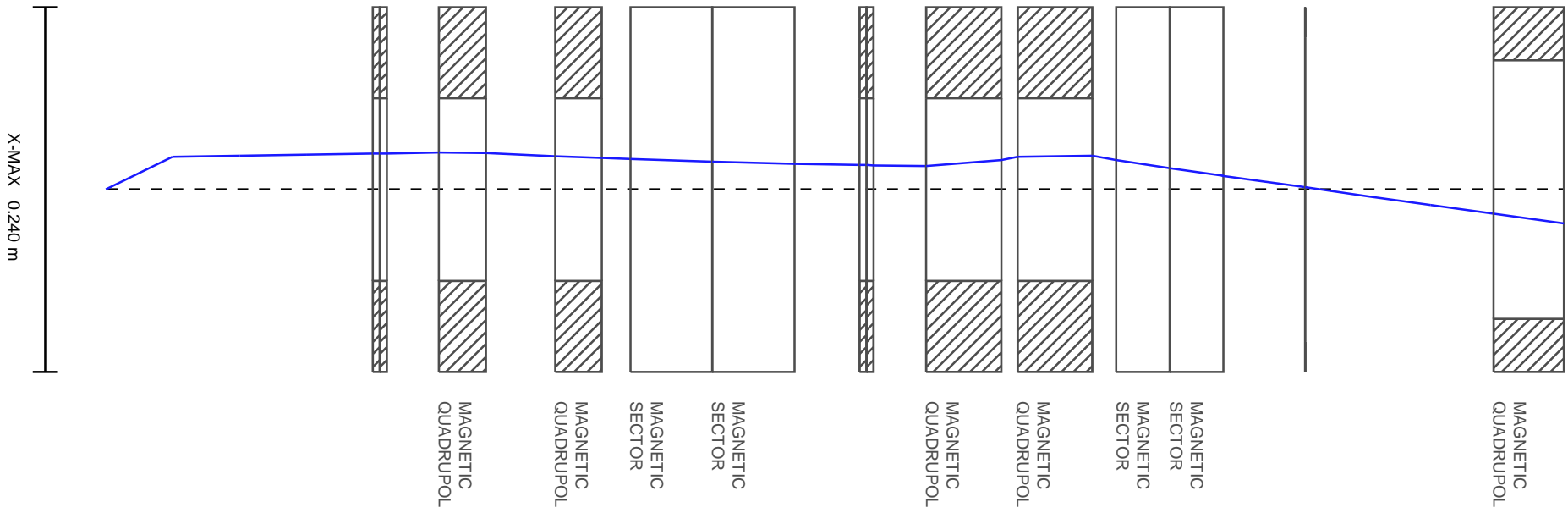

2.000 m

Expression: [X,D]

